



Masterline® Design & Mfg., Inc.

DESIGN SERVICES & PRODUCTS

41580 Production Dr. • Harrison Twp., Michigan 48045 • (586) 463-5888 • Fax (586) 463-8817

**MASTERLINE METRIC EXTRA HEAVY DUTY SHAFT ASSEMBLY WITH LUBE HOLE**

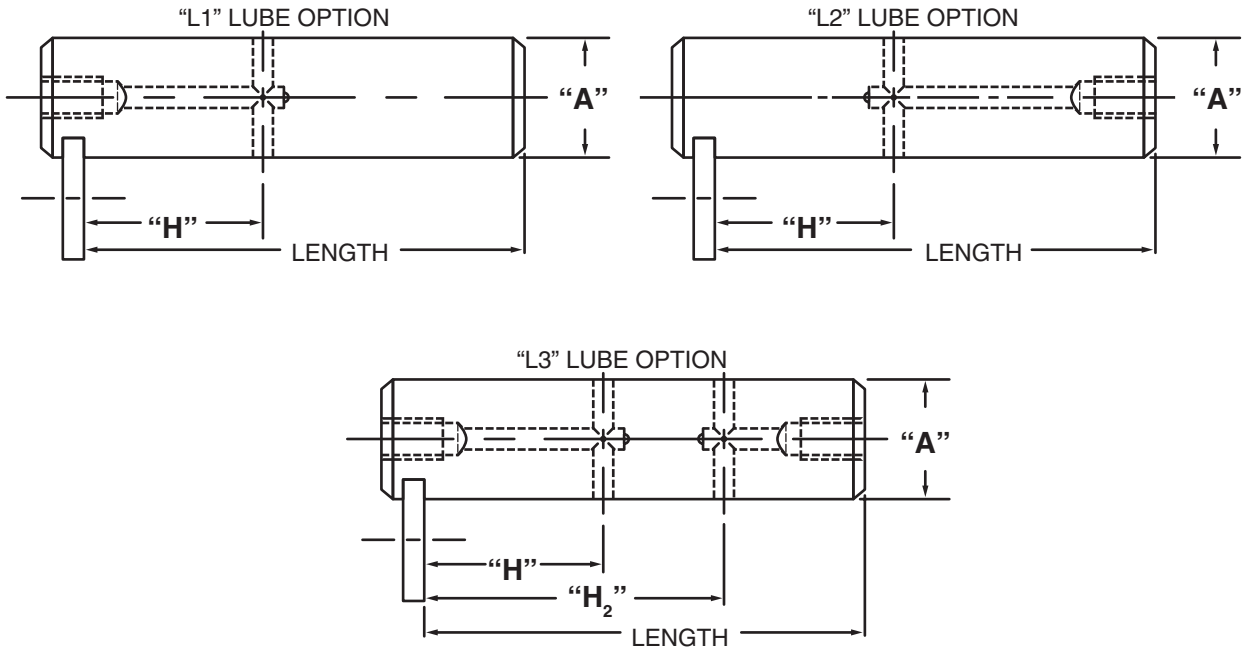

Note: Dimensions to lube holes are taken from inside of slot.

Shafts have 1/8 - 27 N.P.T. in ends. Optional thread for 1/8 - 27 N.P.T. is 1/8 - 28 B.S.P.T.

"L3" option is recommended for use on shafts 250mm or longer when more than one cross-hole is necessary and access to both ends of shaft is possible.

**Masterline Metric Extra Heavy Duty Shaft Assembly with Lube Hole**

(Note: Refer to Section II, page 10 for additional ordering information.)

**How To Order: # 60M x 300M – UH L1 – 20M – 120.5M – Optional Thread**

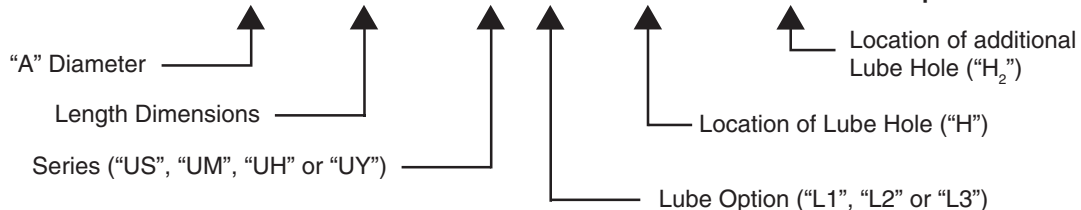

All Parts Available In Inch And Metric.