



Masterline® Design & Mfg., Inc.

DESIGN SERVICES & PRODUCTS

41580 Production Dr. • Harrison Twp., Michigan 48045 • (586) 463-5888 • Fax (586) 463-8817

MASTERLINE METRIC SET SCREW SHAFT WITH LUBE HOLE

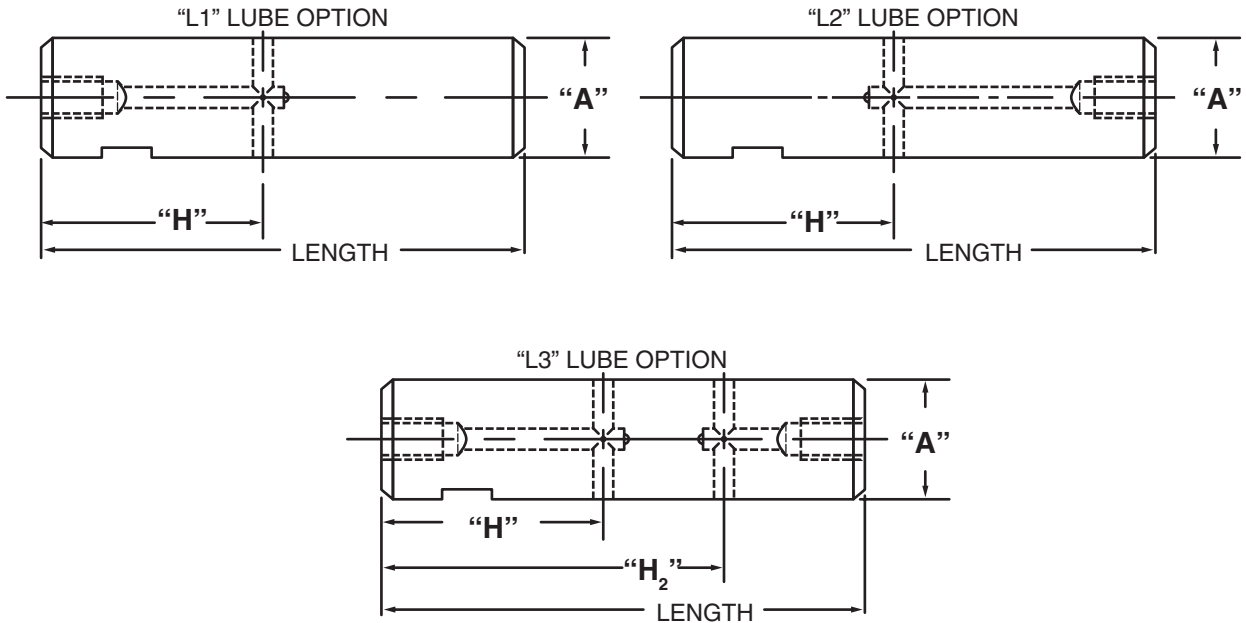

Note: Dimensions to lube holes are taken from inside of slot.

“L1” & “L3” options are not available under 13M dia. shaft

“L1” & “L3” options in 13M – 16M dia. shafts have a 1/4 - 28 tapped hole in the end.

“L2” options in 10M - 16M dia. shafts have a 1/4 - 28 tapped hole in the end.

All other diameter shafts have 1/8 - 27 N.P.T. in ends.

Optional thread for 1/4 – 28 is M6 – 1.0 & optional thread for 1/8 - 27 N.P.T. is 1/8 - 28 B.S.P.T.

“L3” option is recommended for use on shafts 250mm or longer when more than one cross-hole is necessary and access to both ends of shaft is possible.

Masterline Metric Set Screw Shaft with Lube Hole

(Note: Refer to Section II, page 32 for additional ordering information)

How To Order: # 20M x 75M – SH L1 – 13M – 19M – 25M – Optional Thread

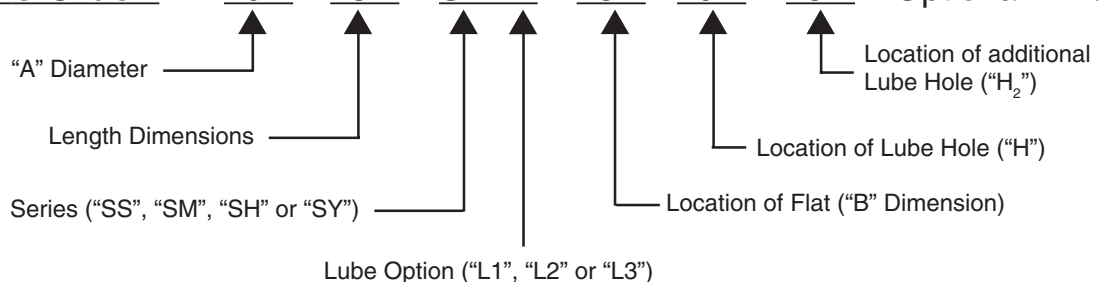

All Parts Available In Inch And Metric.