



Masterline® Design & Mfg., Inc.

DESIGN SERVICES & PRODUCTS

41580 Production Dr. • Harrison Twp., Michigan 48045 • (586) 463-5888 • Fax (586) 463-8817

## MASTERLINE METRIC HEAVY DUTY SHAFT ASSEMBLY WITH LUBE HOLE

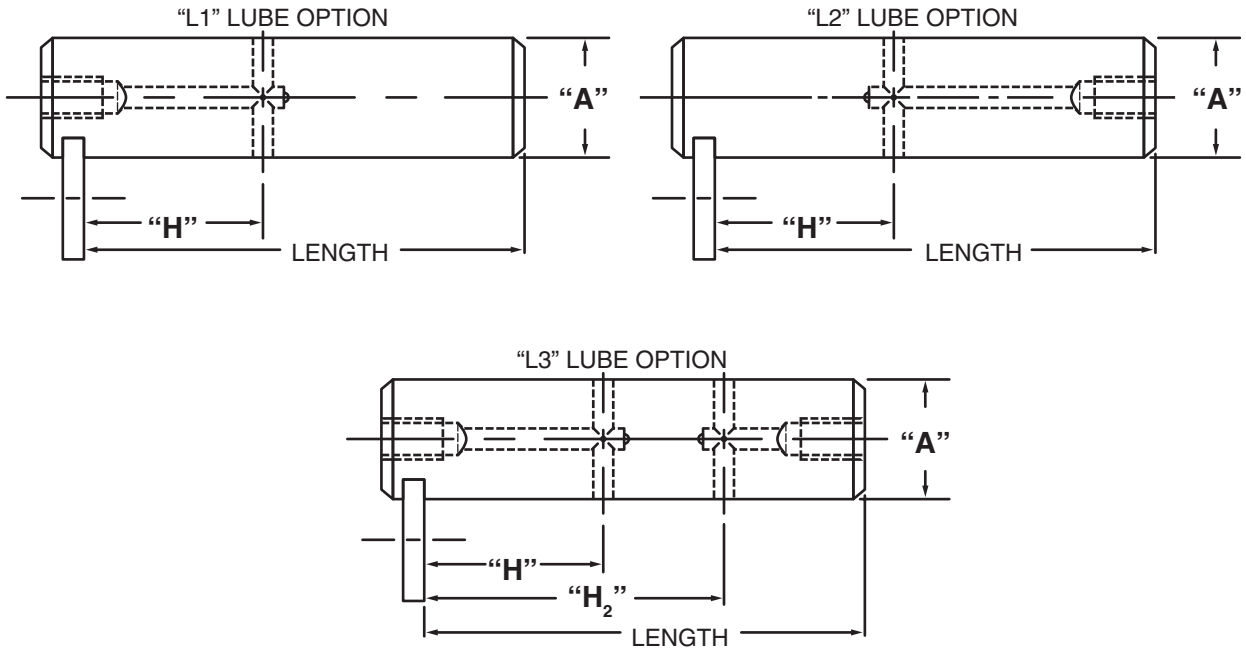

Note: Dimensions to lube holes are taken from inside of slot.

Shafts have 1/8 - 27 N.P.T. in ends. Optional thread for 1/8 - 27 N.P.T. is 1/8 - 28 B.S.P.T.

“L3” option is recommended for use on shafts 250mm or longer when more than one cross-hole is necessary and access to both ends of shaft is possible.

### Masterline Metric Heavy Duty Shaft Assembly with Lube Hole

(Note: Refer to Section II, page 6 for additional ordering information.)

**How To Order:** # 30M HD x 300M - H L1 - 12.5M - 20M - Optional Thread

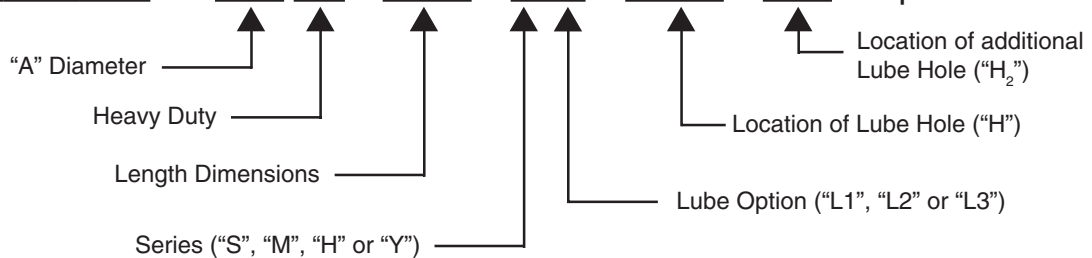

All Parts Available In Inch And Metric.