



Masterline® Design & Mfg., Inc.

DESIGN SERVICES & PRODUCTS

41580 Production Dr. • Harrison Twp., Michigan 48045 • (586) 463-5888 • Fax (586) 463-8817

MASTERLINE HEAD TYPE COTTER PIN SHAFT

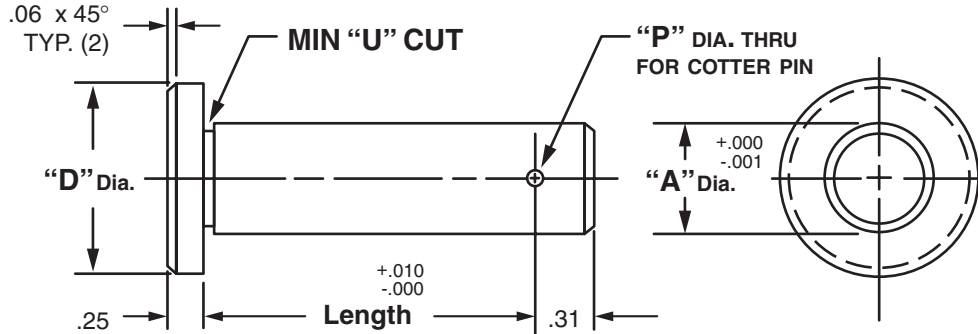

"A" Dia.	"D" Dia.	"P" Dia.	Cad File No.
.250	.50	.07	CZ249
.375	.62	.11	CZ374
.500	1.00	.14	CZ499
.625	1.12	.14	CZ624
.750	1.25	.17	CZ749
.875	1.38	.17	CZ874

"A" Dia.	"D" Dia.	"P" Dia.	Cad File No.
1.000	1.50	.17	CZ999
1.250	1.75	.20	CZ1124
1.250	1.88	.20	CZ1249
1.375	2.00	.23	CZ1374
1.500	2.12	.27	CZ1499

Available in four (4) series:

- "CS" – 12L14 CRS
- "CM" – T.G. & P. Alloy, HDN R_C 28-32
- "CH" – 12L14 CRS, CARB., HDN. & GR., R_C 56-60 (.03 min. case)
- "CY" – 304 Stainless Steel

Other diameters are available on request. (see "How To Order")

Shafts are available with lube holes, lube grooves and extractor option.

(refer to Sec. III, page 15 and Sec. V, page 1 & 4)

Masterline Head Type Cotter Pin Shaft

How To Order:

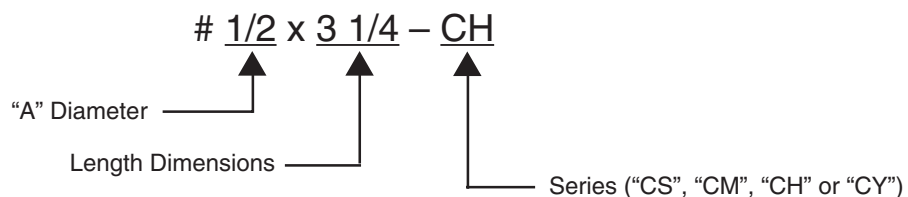

All Parts Available In Inch And Metric.