



Masterline® Design & Mfg., Inc.

DESIGN SERVICES & PRODUCTS

41580 Production Dr. • Harrison Twp., Michigan 48045 • (586) 463-5888 • Fax (586) 463-8817

MASTERLINE HEAD TYPE SNAP RING SHAFT

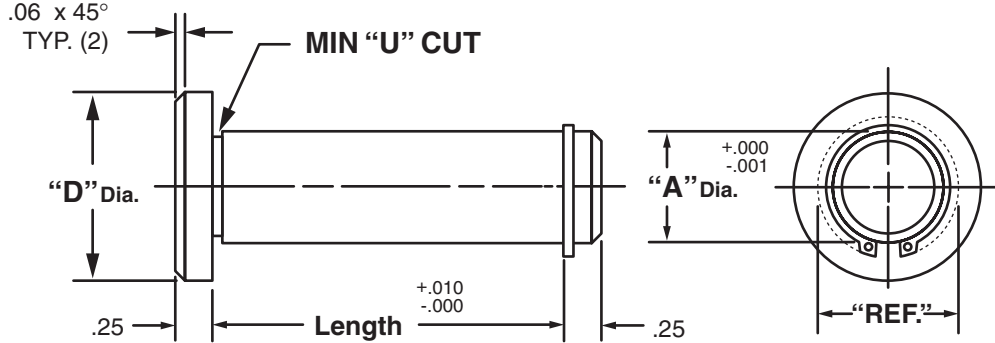

"A" Dia.	"D" Dia.	"REF" Dim.	Cad File No.
.250	.50	.43	HPZ249
.375	.62	.59	HPZ374
.500	1.00	.74	HPZ499
.625	1.12	.87	HPZ624
.750	1.25	1.05	HPZ749
.875	1.38	1.16	HPZ874

"A" Dia.	"D" Dia.	"REF" Dim.	Cad File No.
1.000	1.50	1.35	HPZ999
1.250	1.75	1.49	HPZ1124
1.250	1.88	1.62	HPZ1249
1.375	2.00	1.72	HPZ1374
1.500	2.12	1.90	HPZ1499

Available in four (4) series:

- "HRS" – 12L14 CRS
- "HRM" – T.G. & P. Alloy, HDN R_C 28-32
- "HRH" – 12L14 CRS, CARB., HDN. & GR., R_C 56-60 (.03 min. case)
- "HRY" – 304 Stainless Steel

Each assembly includes one (1) shaft and one (1) snap ring.

NOTE: Snap rings under 1/4" diameter are made of copper/beryllium.

Stainless steel snap rings provided with "HRY" series.

Shafts and snap rings may be ordered separately.

Other diameters are available on request. (see "How To Order")

Shafts are available with lube holes, lube grooves and extractor option.

(refer to Sec. III, page 23 and Sec. V, page 1 & 4)

Masterline Head Type Snap Ring Shaft

How To Order:



All Parts Available In Inch And Metric.